

ECE 2713

Test 2

Thursday, April 21, 2022

12:00 PM - 1:15 PM

Spring 2022

Dr. Havlicek

Name: SOLUTION

Student Num: _____

Directions: This test is closed book and closed notes. Calculators are allowed. You may also use the formula sheet provided with the test. All work must be your own. You have 75 minutes to complete the test.

SHOW ALL OF YOUR WORK for maximum partial credit!

GOOD LUCK!

SCORE:

1. (25) _____

2. (25) _____

3. (25) _____

4. (25) _____

TOTAL (100):

On my honor, I affirm that I have neither given nor received inappropriate aid in the completion of this test.

Name: _____

Date: _____

1. 25 pts. A discrete-time LTI system H has impulse response

$$h[n] = \left(-\frac{1}{3}\right)^n u[n]$$

and input

$$x[n] = \left(\frac{1}{4}\right)^n u[n].$$

Use the discrete-time Fourier transform (DTFT) to find the output signal $y[n]$.

Table: $H(e^{j\omega}) = \frac{1}{1 + \frac{1}{3}e^{-j\omega}}$ $X(e^{j\omega}) = \frac{1}{1 - \frac{1}{4}e^{-j\omega}}$

DTFT Convolution property:

$$Y(e^{j\omega}) = X(e^{j\omega})H(e^{j\omega})$$

$$= \frac{1}{(1 - \frac{1}{4}e^{-j\omega})(1 + \frac{1}{3}e^{-j\omega})} = \frac{A}{1 - \frac{1}{4}e^{-j\omega}} + \frac{B}{1 + \frac{1}{3}e^{-j\omega}}$$

$$A = \frac{1}{1 + \frac{1}{3}\theta} \Big|_{\theta = \frac{4}{3}} = \frac{1}{1 + \frac{4}{3}} = \frac{1}{7/3} = \frac{3}{7}$$

$$B = \frac{1}{1 - \frac{1}{4}\theta} \Big|_{\theta = -3} = \frac{1}{1 + \frac{3}{4}} = \frac{1}{7/4} = \frac{4}{7}$$

$$Y(e^{j\omega}) = \frac{3/7}{1 - \frac{1}{4}e^{-j\omega}} + \frac{4/7}{1 + \frac{1}{3}e^{-j\omega}}$$

Table:

$$y[n] = \frac{3}{7}\left(\frac{1}{4}\right)^n u[n] + \frac{4}{7}\left(-\frac{1}{3}\right)^n u[n]$$

2. 25 pts. A discrete-time LTI system H is formed by connecting three discrete-time LTI systems H_1 , H_2 , and H_3 as shown in the figure below:

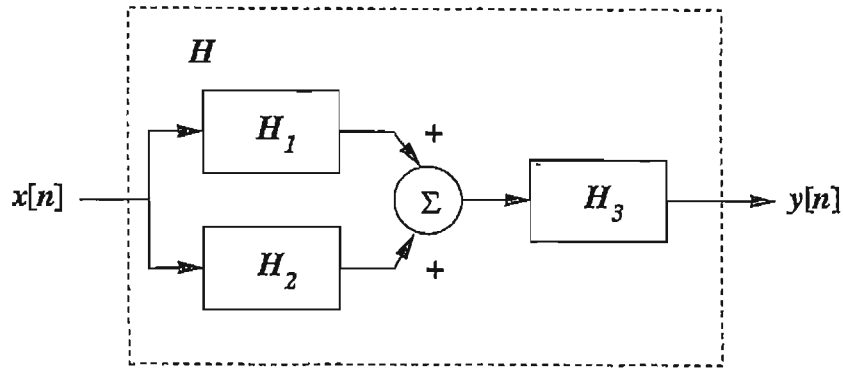

The impulse responses of the individual systems H_1 , H_2 , and H_3 are given by

$$h_1[n] = 3 \left(\frac{1}{2}\right)^n u[n], \quad h_2[n] = 4 \left(\frac{1}{3}\right)^{n-1} u[n-1], \quad h_3[n] = \frac{1}{3} \left(-\frac{1}{2}\right)^n u[n].$$

- (a) 12 pts. Find the overall system frequency response $H(e^{j\omega})$.

Table: $H_1(e^{j\omega}) = \frac{3}{1 - \frac{1}{2}e^{-j\omega}}$ $H_3(e^{j\omega}) = \frac{1/3}{1 + \frac{1}{2}e^{-j\omega}}$

Table plus time shift property: $H_2(e^{j\omega}) = \frac{4e^{-j\omega}}{1 - \frac{1}{3}e^{-j\omega}}$

$$\begin{aligned} H(e^{j\omega}) &= [H_1(e^{j\omega}) + H_2(e^{j\omega})] H_3(e^{j\omega}) = \left[\frac{3}{1 - \frac{1}{2}e^{-j\omega}} + \frac{4e^{-j\omega}}{1 - \frac{1}{3}e^{-j\omega}} \right] \frac{1/3}{1 + \frac{1}{2}e^{-j\omega}} \\ &= \frac{3(1 - \frac{1}{3}e^{-j\omega}) + 4(1 - \frac{1}{2}e^{-j\omega})e^{-j\omega}}{(1 - \frac{1}{2}e^{-j\omega})(1 - \frac{1}{3}e^{-j\omega})} \cdot \frac{1/3}{1 + \frac{1}{2}e^{-j\omega}} \\ &= \frac{[3 - e^{-j\omega} + 4e^{-j\omega} - 2e^{-j2\omega}] \frac{1}{3}}{(1 - \frac{1}{2}e^{-j\omega})(1 - \frac{1}{3}e^{-j\omega})(1 + \frac{1}{2}e^{-j\omega})} = \frac{[3 + 3e^{-j\omega} - 2e^{-j2\omega}] \frac{1}{3}}{(1 - \frac{1}{2}e^{-j\omega})(1 - \frac{1}{3}e^{-j\omega})(1 + \frac{1}{2}e^{-j\omega})} \end{aligned}$$

$$H(e^{j\omega}) = \frac{1 + e^{-j\omega} - \frac{2}{3}e^{-j2\omega}}{(1 - \frac{1}{2}e^{-j\omega})(1 - \frac{1}{3}e^{-j\omega})(1 + \frac{1}{2}e^{-j\omega})}$$

Problem 2, cont...

(b) 13 pts. Find the overall system impulse response $h[n]$.

$$H(e^{j\omega}) = \frac{1 + e^{-j\omega} - \frac{2}{3}e^{-j2\omega}}{(1 - \frac{1}{2}e^{-j\omega})(1 - \frac{1}{3}e^{-j\omega})(1 + \frac{1}{2}e^{-j\omega})}$$

$$= \frac{A}{1 - \frac{1}{2}e^{-j\omega}} + \frac{B}{1 - \frac{1}{3}e^{-j\omega}} + \frac{C}{1 + \frac{1}{2}e^{-j\omega}}$$

$$A = \frac{1 + \theta - \frac{2}{3}\theta^2}{(1 - \frac{1}{3}\theta)(1 + \frac{1}{2}\theta)} \Big|_{\theta=2} = \frac{1 + 2 - \frac{8}{3}}{(1 - \frac{2}{3})(1 + 1)} = \frac{3 - \frac{8}{3}}{(\frac{1}{3})(2)} = \frac{9/3 - 8/3}{2/3} = \frac{1}{2} \quad |||$$

$$B = \frac{1 + \theta - \frac{2}{3}\theta^2}{(1 - \frac{1}{2}\theta)(1 + \frac{1}{2}\theta)} \Big|_{\theta=3} = \frac{1 + 3 - \frac{2}{3} \cdot 9}{(1 - \frac{3}{2})(1 + \frac{3}{2})} = \frac{4 - 6}{(-\frac{1}{2})(\frac{5}{2})} = \frac{-2}{-\frac{5}{4}} = \frac{8}{5} \quad |||$$

$$C = \frac{1 + \theta - \frac{2}{3}\theta^2}{(1 - \frac{1}{2}\theta)(1 - \frac{1}{3}\theta)} \Big|_{\theta=-2} = \frac{1 - 2 - \frac{2}{3} \cdot 4}{(1 + 1)(1 + \frac{2}{3})} = \frac{-1 - \frac{8}{3}}{2(\frac{5}{3})} = \frac{-\frac{3}{3} - \frac{8}{3}}{10/3} = -\frac{11}{10} \quad |||$$

$$H(e^{j\omega}) = \frac{\frac{1}{2}}{1 - \frac{1}{2}e^{-j\omega}} + \frac{\frac{8}{5}}{1 - \frac{1}{3}e^{-j\omega}} - \frac{\frac{11}{10}}{1 + \frac{1}{2}e^{-j\omega}}$$

Table:

$$h[n] = \frac{1}{2} \left(\frac{1}{2}\right)^n u[n] + \frac{8}{5} \left(\frac{1}{3}\right)^n u[n] - \frac{11}{10} \left(-\frac{1}{2}\right)^n u[n]$$

3. 25 pts. Consider the discrete-time LTI system H shown below.

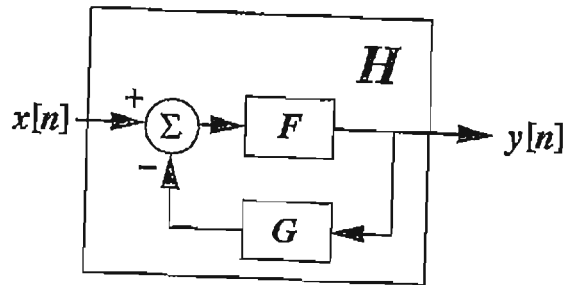

F and G are both discrete-time LTI systems.

Table:

The impulse response of F is given by $f[n] = (n+1) \left(\frac{1}{2}\right)^n u[n]$. $F(e^{j\omega}) = \frac{1}{(1-\frac{1}{2}e^{-j\omega})^2}$

The impulse response of G is given by $g[n] = \left(\frac{1}{4}\right)^n u[n]$. $G(e^{j\omega}) = \frac{1}{1-\frac{1}{4}e^{-j\omega}}$

(a) 13 pts. Find the overall system frequency response $H(e^{j\omega})$.

$$\begin{aligned}
 H(e^{j\omega}) &= \frac{F(e^{j\omega})}{1 + F(e^{j\omega})G(e^{j\omega})} = \frac{\frac{1}{(1-\frac{1}{2}e^{-j\omega})^2}}{1 + \frac{1}{(1-\frac{1}{2}e^{-j\omega})^2(1-\frac{1}{4}e^{-j\omega})}} \\
 &= \frac{\frac{1}{(1-\frac{1}{2}e^{-j\omega})^2}}{1 + \frac{1}{(1-\frac{1}{2}e^{-j\omega})^2(1-\frac{1}{4}e^{-j\omega})}} \cdot \frac{(1-\frac{1}{2}e^{-j\omega})^2(1-\frac{1}{4}e^{-j\omega})}{(1-\frac{1}{2}e^{-j\omega})^2(1-\frac{1}{4}e^{-j\omega})} \\
 &= \frac{1-\frac{1}{4}e^{-j\omega}}{(1-\frac{1}{2}e^{-j\omega})^2(1-\frac{1}{4}e^{-j\omega}) + 1} = \frac{1-\frac{1}{4}e^{-j\omega}}{(1-e^{-j\omega} + \frac{1}{4}e^{-j2\omega})(1-\frac{1}{4}e^{-j\omega}) + 1} \\
 &= \frac{1-\frac{1}{4}e^{-j\omega}}{1-e^{-j\omega} + \frac{1}{4}e^{-j2\omega} - \frac{1}{4}e^{-j\omega} + \frac{1}{4}e^{-j2\omega} - \frac{1}{16}e^{-j3\omega} + 1}
 \end{aligned}$$

$$H(e^{j\omega}) = \frac{1-\frac{1}{4}e^{-j\omega}}{2 - \frac{5}{4}e^{-j\omega} + \frac{1}{2}e^{-j2\omega} - \frac{1}{16}e^{-j3\omega}}$$

Problem 3, cont...

- (b) 12 pts. Find the difference equation (I/O equation) that relates the input $x[n]$ and output $y[n]$ of the overall system H .

$$H(e^{j\omega}) = \frac{Y(e^{j\omega})}{X(e^{j\omega})} = \frac{1 - \frac{1}{4}e^{-j\omega}}{2 - \frac{5}{4}e^{-j\omega} + \frac{1}{2}e^{-j2\omega} - \frac{1}{16}e^{-j3\omega}}$$

$$Y(e^{j\omega}) \left[2 - \frac{5}{4}e^{-j\omega} + \frac{1}{2}e^{-j2\omega} - \frac{1}{16}e^{-j3\omega} \right] = X(e^{j\omega}) \left[1 - \frac{1}{4}e^{-j\omega} \right]$$

$$\begin{aligned} 2Y(e^{j\omega}) - \frac{5}{4}e^{-j\omega} Y(e^{j\omega}) + \frac{1}{2}e^{-j2\omega} Y(e^{j\omega}) - \frac{1}{16}e^{-j3\omega} Y(e^{j\omega}) \\ = X(e^{j\omega}) - \frac{1}{4}e^{-j\omega} X(e^{j\omega}) \end{aligned}$$

IDTFT:

$$2y[n] - \frac{5}{4}y[n-1] + \frac{1}{2}y[n-2] - \frac{1}{16}y[n-3] = x[n] - \frac{1}{4}x[n-1]$$

4. 25 pts. A linear phase FIR digital filter H has impulse response

$$h[n] = \delta[n] - \delta[n-1] + 4\delta[n-2] - \delta[n-3] + \delta[n-4].$$

(a) 10 pts. Find the filter frequency response $H(e^{j\omega})$.

Table plus time shift property:

$$H(e^{j\omega}) = 1 - e^{-j\omega} + 4e^{-j2\omega} - e^{-j3\omega} + e^{-j4\omega}$$

Problem 4, cont...

(b) 15 pts. Find the filter magnitude response $|H(e^{j\omega})|$ and phase response $\arg H(e^{j\omega})$.

Hint: use the FIR "linear phase trick" to write $H(e^{j\omega})$ in polar form and then simply read off the magnitude response and phase response.

Highest Power = $e^{-j4\omega}$. Half the highest power = $e^{-j2\omega}$

→ Factor out half the highest power:

$$\begin{aligned} H(e^{j\omega}) &= [e^{j2\omega} - e^{j\omega} + 4 - e^{-j\omega} + e^{-j2\omega}] e^{-j2\omega} \\ &= [(e^{j2\omega} + e^{-j2\omega}) - (e^{j\omega} + e^{-j\omega}) + 4] e^{-j2\omega} \\ &= \underbrace{[2\cos(2\omega) - 2\cos\omega + 4]}_{|H(e^{j\omega})|} \underbrace{e^{-j2\omega}}_{e^{j\arg H(e^{j\omega})}} \end{aligned}$$

$$|H(e^{j\omega})| = 2\cos(2\omega) - 2\cos(\omega) + 4$$

$$\arg H(e^{j\omega}) = -2\omega$$