

Formulas from Trigonometry:

$$\sin^2 A + \cos^2 A = 1$$

$$\cos(A \pm B) = \cos A \cos B \mp \sin A \sin B$$

$$\sin 2A = 2 \sin A \cos A$$

$$\tan 2A = \frac{2 \tan A}{1 - \tan^2 A}$$

$$\cos \frac{A}{2} = \pm \sqrt{\frac{1 + \cos A}{2}}$$

$$\sin^2 A = \frac{1}{2} - \frac{1}{2} \cos 2A$$

$$\sin A + \sin B = 2 \sin \frac{1}{2}(A + B) \cos \frac{1}{2}(A - B)$$

$$\cos A + \cos B = 2 \cos \frac{1}{2}(A + B) \cos \frac{1}{2}(A - B)$$

$$\sin A \sin B = \frac{1}{2} \{ \cos(A - B) - \cos(A + B) \}$$

$$\sin A \cos B = \frac{1}{2} \{ \sin(A - B) + \sin(A + B) \}$$

$$\sin(A \pm B) = \sin A \cos B \pm \cos A \sin B$$

$$\tan(A \pm B) = \frac{\tan A \pm \tan B}{1 \mp \tan A \tan B}$$

$$\cos 2A = \cos^2 A - \sin^2 A$$

$$\sin \frac{A}{2} = \pm \sqrt{\frac{1 - \cos A}{2}}$$

$$\tan \frac{A}{2} = \frac{\sin A}{1 + \cos A}$$

$$\cos^2 A = \frac{1}{2} + \frac{1}{2} \cos 2A$$

$$\sin A - \sin B = 2 \cos \frac{1}{2}(A + B) \sin \frac{1}{2}(A - B)$$

$$\cos A - \cos B = 2 \sin \frac{1}{2}(A + B) \sin \frac{1}{2}(B - A)$$

$$\cos A \cos B = \frac{1}{2} \{ \cos(A - B) + \cos(A + B) \}$$

$$\cos(\theta) = \sin(\theta + \pi/2)$$

Differentiation Formulas:

$$\frac{d}{dx}(uv) = u \frac{dv}{dx} + \frac{du}{dx} v$$

$$\text{Chain rule: } \frac{dy}{dx} = \frac{dy}{du} \frac{du}{dx}$$

$$\frac{d}{dx} \cos u = -\sin u \frac{du}{dx}$$

$$\frac{d}{dx} \sin^{-1} u = \frac{1}{\sqrt{1-u^2}} \frac{du}{dx}, \quad \left(-\frac{\pi}{2} < \sin^{-1} u < \frac{\pi}{2}\right)$$

$$\frac{d}{dx} \tan^{-1} u = \frac{1}{1+u^2} \frac{du}{dx}, \quad \left(-\frac{\pi}{2} < \tan^{-1} u < \frac{\pi}{2}\right)$$

$$\frac{d}{dx} \ln u = \frac{1}{u} \frac{du}{dx}$$

$$\frac{d}{dx} \left(\frac{u}{v}\right) = \frac{v(du/dx) - u(dv/dx)}{v^2}$$

$$\frac{d}{dx} \sin u = \cos u \frac{du}{dx}$$

$$\frac{d}{dx} \tan u = \sec^2 u \frac{du}{dx}$$

$$\frac{d}{dx} \cos^{-1} u = \frac{-1}{\sqrt{1-u^2}} \frac{du}{dx}, \quad (0 < \cos^{-1} u < \pi)$$

$$\frac{d}{dx} e^u = e^u \frac{du}{dx}$$

$$\frac{d}{dx} \log_a u = \frac{\log_a e}{u} \frac{du}{dx}, \quad a \neq 0, 1$$

Integration Formulas:

$$\text{Integration by parts: } \int u dv = uv - \int v du$$

$$\int \frac{du}{u} = \ln |u|$$

$$\int a^u du = \frac{a^u}{\ln a}, \quad a > 0, a \neq 1$$

$$\int \cos u du = \sin u$$

$$\int \sin^2 u du = \frac{u}{2} - \frac{\sin 2u}{4} = \frac{1}{2}(u - \sin u \cos u)$$

$$\int \cos^2 u du = \frac{u}{2} + \frac{\sin 2u}{4} = \frac{1}{2}(u + \sin u \cos u)$$

$$\int \frac{du}{u^2 - a^2} = \frac{1}{2a} \ln \left(\frac{u-a}{u+a} \right)$$

$$\int \frac{du}{\sqrt{u^2 + a^2}} = \ln(u + \sqrt{u^2 + a^2})$$

$$\int e^{ax} \sin bx dx = \frac{e^{ax}(a \sin bx - b \cos bx)}{a^2 + b^2}$$

$$\int x \sin ax dx = \frac{\sin ax}{a^2} - \frac{x \cos ax}{a}$$

$$\int \sin^2 ax dx = \frac{x}{2} - \frac{\sin 2ax}{4a}$$

$$\int x^2 \cos ax dx = \frac{2x}{a^2} \cos ax + \left(\frac{x^2}{a} - \frac{2}{a^3} \right) \sin ax$$

$$\int \tan^2 ax dx = \frac{\tan ax}{a} - x$$

$$\int \ln x dx = x \ln x - x$$

$$\int e^u du = e^u$$

$$\int \sin u du = -\cos u$$

$$\int \tan u du = -\ln |\cos u|$$

$$\int \tan^2 u du = \tan u - u$$

$$\int \frac{du}{u^2 + a^2} = \frac{1}{a} \tan^{-1} \frac{u}{a}$$

$$\int \frac{du}{\sqrt{a^2 - u^2}} = \sin^{-1} \frac{u}{a}$$

$$\int \frac{du}{\sqrt{u^2 - a^2}} = \ln(u + \sqrt{u^2 - a^2})$$

$$\int e^{ax} \cos bx dx = \frac{e^{ax}(a \cos bx + b \sin bx)}{a^2 + b^2}$$

$$\int x^2 \sin ax dx = \frac{2x}{a^2} \sin ax + \left(\frac{2}{a^3} - \frac{x^2}{a} \right) \cos ax$$

$$\int x \cos ax dx = \frac{\cos ax}{a^2} + \frac{x \sin ax}{a}$$

$$\int \cos^2 ax dx = \frac{x}{2} + \frac{\sin 2ax}{4a}$$

$$\int x e^{ax} dx = \frac{e^{ax}}{a} \left(x - \frac{1}{a} \right)$$

$$\int x \ln x dx = \frac{x^2}{2} \left(\ln x - \frac{1}{2} \right)$$

Rules for Exponents:

$$\begin{aligned} a^{b+c} &= a^b a^c & (ab)^c &= a^c b^c \\ (a^b)^c &= a^{bc} & a^{-b} &= \left(\frac{1}{a}\right)^b = \frac{1}{a^b} \end{aligned}$$

Taylor Series:

$$\begin{aligned} e^x &= 1 + x + \frac{x^2}{2!} + \frac{x^3}{3!} + \frac{x^4}{4!} + \dots = \sum_{n=0}^{\infty} \frac{x^n}{n!} \\ \cos x &= 1 - \frac{x^2}{2!} + \frac{x^4}{4!} - \frac{x^6}{6!} + \dots = \sum_{n=0}^{\infty} \frac{(-1)^n x^{2n}}{(2n)!} \\ \sin x &= x - \frac{x^3}{3!} + \frac{x^5}{5!} - \frac{x^7}{7!} + \dots = \sum_{n=0}^{\infty} \frac{(-1)^n x^{2n+1}}{(2n+1)!} \end{aligned}$$

Euler's Formula:

$$\begin{aligned} e^{j\theta} &= \cos \theta + j \sin \theta \\ \cos \theta &= \frac{e^{j\theta} + e^{-j\theta}}{2} & \sin \theta &= \frac{e^{j\theta} - e^{-j\theta}}{2j} \end{aligned}$$

Rectangular and Polar Form of a Complex Number:

$$\begin{aligned} z &= a + jb = r e^{j\theta} \\ r &= |z| = \sqrt{a^2 + b^2} & a &= \operatorname{Re}\{z\} = r \cos \theta \\ r^2 &= z z^* & a &= \operatorname{Re}\{z\} = \frac{z + z^*}{2} \\ \theta &= \arctan \frac{b}{a} & b &= \operatorname{Im}\{z\} = r \sin \theta \\ & & b &= \operatorname{Im}\{z\} = \frac{z - z^*}{2j} \end{aligned}$$

Phasors:

$$\begin{aligned} \text{Complex Signal:} & \quad z(t) = A e^{j(\omega_0 t + \phi)} = A e^{j\phi} e^{j\omega_0 t} \\ \text{Real Signal:} & \quad x(t) = \operatorname{Re}\{z(t)\} = A \cos(\omega_0 t + \phi) \\ \text{Phasor Representation:} & \quad X = A e^{j\phi} \end{aligned}$$

Phasor Addition:

Let $x_1(t) = A_1 \cos(\omega_0 t + \phi_1)$, $x_2(t) = A_2 \cos(\omega_0 t + \phi_2)$, and $x(t) = x_1(t) + x_2(t)$.
Then $x(t) = A \cos(\omega_0 t + \phi)$ and:
the phasor representation for $x(t)$ is $X = A e^{j\phi} = A_1 e^{j\phi_1} + A_2 e^{j\phi_2}$.

Continuous-Time Unit Impulse and Unit Step:

$$\begin{aligned} \int_{-\infty}^{\infty} \delta(t) dt &= 1 & \int_{-\infty}^{\infty} x(t) \delta(t) dt &= x(0) & \int_{-\infty}^{\infty} x(t) \delta(t - t_0) dt &= x(t_0) \\ u(t) &= \int_{-\infty}^t \delta(t) dt \end{aligned}$$

Discrete-Time Unit Impulse and Unit Step:

$$\delta[n] = \begin{cases} 1, & n = 0, \\ 0, & \text{otherwise.} \end{cases} \quad u[n] = \begin{cases} 1, & n \geq 0, \\ 0, & n < 0. \end{cases}$$

Complex Exponential Signals:

$e^{j\omega_0 t}$	$e^{j\omega_0 n}$
Distinct signals for distinct w_0	Identical signals for values of w_0 separated by multiples of 2π
Periodic for any choice of w_0	Periodic only if $w_0/(2\pi) = m/N \in \mathbb{Q}$
Fundamental frequency w_0	Fundamental frequency w_0/m
Fundamental period: $w_0 = 0$: undefined $w_0 \neq 0$: $2\pi/w_0$	Fundamental period: $w_0 = 0$: one $w_0 \neq 0$: $N = 2\pi m/w_0$

Periodicity of Discrete-Time Sinusoids:

$\cos(\omega_0 n)$, $\sin(\omega_0 n)$, and $e^{j\omega_0 n}$ are periodic if and only if $\frac{w_0}{2\pi}$ is a ratio of two integers.

If periodic, then write in reduced form: $\frac{w_0}{2\pi} = \frac{m}{N}$ (no common factors between m and N)

N : Fundamental Period

m : In each period of the discrete-time signal, the graph “goes around” m times.

Summation Formulas:

$$\sum_{k=N_1}^{N_2} \alpha^k = \frac{\alpha^{N_1} - \alpha^{N_2+1}}{1 - \alpha}, \quad \alpha \neq 1$$

$$\sum_{k=0}^{\infty} a^k = \frac{1}{1 - a}, \quad |a| < 1$$

$$\sum_{k=0}^{\infty} k a^k = \frac{a}{(1 - a)^2}, \quad |a| < 1$$

$$\sum_{k=0}^n a^k = \frac{1 - a^{n+1}}{1 - a}, \quad a \neq 1$$

$$\sum_{k=0}^n k a^k = \frac{a\{1 - (n+1)a^n + n a^{n+1}\}}{(1 - a)^2}$$

Time Domain Representation of Discrete-Time Signals:

$$\begin{aligned} x[n] &= \cdots + x[-2]\delta[n+2] + x[-1]\delta[n+1] + x[0]\delta[n] + x[1]\delta[n-1] + x[2]\delta[n-2] + \cdots \\ &= \sum_{k=-\infty}^{\infty} x[k]\delta[n-k]. \end{aligned}$$

Systems:

- System H is linear if $H\{ax_1[n] + bx_2[n]\} = aH\{x_1[n]\} + bH\{x_2[n]\}$.
- System H is time invariant if $H\{x[n - n_0]\} = y[n - n_0]$.
- Impulse response: for LTI system H , $h[n] = H\{\delta[n]\}$.
- System H is causal if the current output does not depend on future inputs.
- LTI system H is causal iff $h[n] = 0 \forall n < 0$.
- System H is stable if every bounded input signal produces a bounded output signal.

Convolution:

$$y[n] = x[n] * h[n] = \sum_{k=-\infty}^{\infty} x[k]h[n-k] = \sum_{k=-\infty}^{\infty} x[n-k]h[k]$$

Convolution with $\delta[n]$:

$$x[n] * \delta[n] = x[n] \qquad x[n] * \delta[n - n_0] = x[n - n_0].$$

LTI System Interconnections:

Series/Cascade

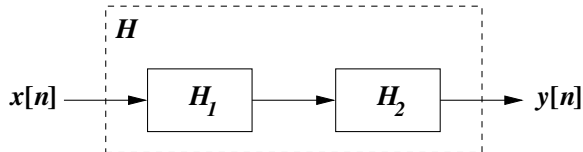

$$h[n] = h_1[n] * h_2[n]$$

$$H(e^{j\omega}) = H_1(e^{j\omega})H_2(e^{j\omega})$$

$$H(z) = H_1(z)H_2(z)$$

Parallel

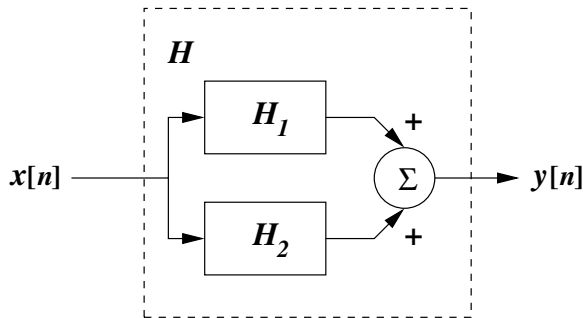

$$h[n] = h_1[n] + h_2[n]$$

$$H(e^{j\omega}) = H_1(e^{j\omega}) + H_2(e^{j\omega})$$

$$H(z) = H_1(z) + H_2(z)$$

Negative Feedback

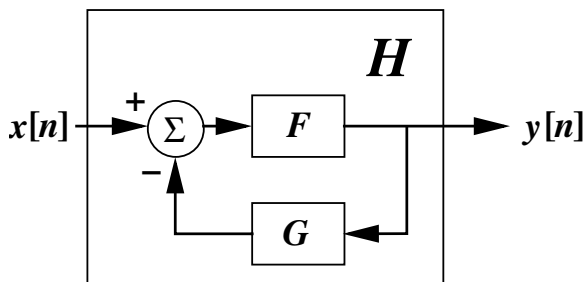

$h[n]$: No general expression

$$H(e^{j\omega}) = \frac{F(e^{j\omega})}{1 + F(e^{j\omega})G(e^{j\omega})}$$

$$H(z) = \frac{F(z)}{1 + F(z)G(z)}$$

ROC of $H(z)$:

- If H is a **causal** discrete-time LTI system, then the ROC of $H(z)$ is **exterior**.
- A discrete-time LTI system H is **stable** if and only if the ROC of $H(z)$ contains the unit-circle of the z -plane. (This is *assuming* that $H(z)$ is a ratio of two polynomials in z^{-1})

Basic Discrete-Time Fourier Transform Pairs:

Signal	Fourier transform
$\sum_{k=(N)} a_k e^{jk(2\pi/N)n}$	$2\pi \sum_{k=-\infty}^{\infty} a_k \delta\left(\omega - \frac{2\pi k}{N}\right)$
$e^{j\omega_0 n}$	$2\pi \sum_{l=-\infty}^{\infty} \delta(\omega - \omega_0 - 2\pi l)$
$\cos \omega_0 n$	$\pi \sum_{l=-\infty}^{\infty} \{\delta(\omega - \omega_0 - 2\pi l) + \delta(\omega + \omega_0 - 2\pi l)\}$
$\sin \omega_0 n$	$\frac{\pi}{j} \sum_{l=-\infty}^{\infty} \{\delta(\omega - \omega_0 - 2\pi l) - \delta(\omega + \omega_0 - 2\pi l)\}$
$x[n] = 1$	$2\pi \sum_{l=-\infty}^{\infty} \delta(\omega - 2\pi l)$
Periodic square wave $x[n] = \begin{cases} 1, & n < N_1 \\ 0, & N_1 < n \leq N/2 \end{cases}$ and $x[n + N] = x[n]$	$2\pi \sum_{k=-\infty}^{\infty} a_k \delta\left(\omega - \frac{2\pi k}{N}\right)$
$\sum_{k=-\infty}^{\infty} \delta[n - kN]$	$\frac{2\pi}{N} \sum_{k=-\infty}^{\infty} \delta\left(\omega - \frac{2\pi k}{N}\right)$
$a^n u[n], \quad a < 1$	$\frac{1}{1 - ae^{-j\omega}}$
$x[n] = \begin{cases} 1, & n \leq N_1 \\ 0, & n > N_1 \end{cases}$	$\frac{\sin[\omega(N_1 + \frac{1}{2})]}{\sin(\omega/2)}$
$\frac{\sin Wn}{\pi n}, \quad 0 < W < \pi$	$X(e^{j\omega}) = \begin{cases} 1, & 0 \leq \omega \leq W \\ 0, & W < \omega \leq \pi \end{cases}$ $X(e^{j\omega})$ is 2π -periodic
$\delta[n]$	1
$u[n]$	$\frac{1}{1 - e^{-j\omega}} + \sum_{k=-\infty}^{\infty} \pi \delta(\omega - 2\pi k)$
$\delta[n - n_0]$	$e^{-j\omega n_0}$
$(n + 1)a^n u[n], \quad a < 1$	$\frac{1}{(1 - ae^{-j\omega})^2}$
$\frac{(n+r-1)!}{n!(r-1)!} a^n u[n], \quad a < 1$	$\frac{1}{(1 - ae^{-j\omega})^r}$

Properties of the Discrete-Time Fourier Transform:

$$X(e^{j\omega}) = \sum_{n=-\infty}^{\infty} x[n]e^{-j\omega n} \qquad x[n] = \frac{1}{2\pi} \int_{2\pi} X(e^{j\omega})e^{j\omega n} d\omega$$

Property	Aperiodic signal	Fourier transform
Linearity	$ax[n] + by[n]$	$aX(e^{j\omega}) + bY(e^{j\omega})$
Time Shifting	$x[n - n_0]$	$e^{-j\omega n_0} X(e^{j\omega})$
Frequency Shifting	$e^{j\omega_0 n} x[n]$	$X(e^{j(\omega - \omega_0)})$
Conjugation	$x^*[n]$	$X^*(e^{-j\omega})$
Time Reversal	$x[-n]$	$X(e^{-j\omega})$
Time Expansion	$x_{(k)}[n] = \begin{cases} x[n/k], & \text{if } n = \text{multiple of } k \\ 0, & \text{if } n \neq \text{multiple of } k \end{cases}$	$X(e^{jk\omega})$
Convolution	$x[n] * y[n]$	$X(e^{j\omega})Y(e^{j\omega})$
Multiplication	$x[n]y[n]$	$\frac{1}{2\pi} \int_{2\pi} X(e^{j\theta})Y(e^{j(\omega - \theta)}) d\theta$
Differencing in Time	$x[n] - x[n - 1]$	$(1 - e^{-j\omega})X(e^{j\omega})$
Accumulation	$\sum_{k=-\infty}^n x[k]$	$\frac{1}{1 - e^{-j\omega}} X(e^{j\omega})$
Differentiation in Frequency	$nx[n]$	$j \frac{d}{d\omega} X(e^{j\omega})$
Conjugate Symmetry for Real Signals	$x[n]$ real	$\begin{cases} X(e^{j\omega}) = X^*(e^{-j\omega}) \\ \text{Re}\{X(e^{j\omega})\} = \text{Re}\{X(e^{-j\omega})\} \\ \text{Im}\{X(e^{j\omega})\} = -\text{Im}\{X(e^{-j\omega})\} \\ X(e^{j\omega}) = X(e^{-j\omega}) \\ \angle X(e^{j\omega}) = -\angle X(e^{-j\omega}) \end{cases}$
Symmetry for Real and Even Signals	$x[n]$ real and even	$X(e^{j\omega})$ real and even
Symmetry for Real and Odd Signals	$x[n]$ real and odd	$X(e^{j\omega})$ purely imaginary and odd
Even-Odd Decomposition for Real Signals	$x_e[n] = \mathcal{E}v\{x[n]\}$ [$x[n]$ real] $x_o[n] = \mathcal{O}d\{x[n]\}$ [$x[n]$ real]	$\text{Re}\{X(e^{j\omega})\}$ $j\text{Im}\{X(e^{j\omega})\}$

Parseval's Relation for Aperiodic Signals

$$\sum_{n=-\infty}^{\infty} |x[n]|^2 = \frac{1}{2\pi} \int_{2\pi} |X(e^{j\omega})|^2 d\omega$$

Common z -Transform Pairs:

Signal	Transform	ROC
$\delta[n]$	1	All z
$u[n]$	$\frac{1}{1 - z^{-1}}$	$ z > 1$
$-u[-n - 1]$	$\frac{1}{1 - z^{-1}}$	$ z < 1$
$\delta[n - m]$	z^{-m}	All z , except 0 (if $m > 0$) or ∞ (if $m < 0$)
$\alpha^n u[n]$	$\frac{1}{1 - \alpha z^{-1}}$	$ z > \alpha $
$-\alpha^n u[-n - 1]$	$\frac{1}{1 - \alpha z^{-1}}$	$ z < \alpha $
$n\alpha^n u[n]$	$\frac{\alpha z^{-1}}{(1 - \alpha z^{-1})^2}$	$ z > \alpha $
$-n\alpha^n u[-n - 1]$	$\frac{\alpha z^{-1}}{(1 - \alpha z^{-1})^2}$	$ z < \alpha $
$[\cos \omega_0 n]u[n]$	$\frac{1 - [\cos \omega_0]z^{-1}}{1 - [2 \cos \omega_0]z^{-1} + z^{-2}}$	$ z > 1$
$[\sin \omega_0 n]u[n]$	$\frac{[\sin \omega_0]z^{-1}}{1 - [2 \cos \omega_0]z^{-1} + z^{-2}}$	$ z > 1$
$[r^n \cos \omega_0 n]u[n]$	$\frac{1 - [r \cos \omega_0]z^{-1}}{1 - [2r \cos \omega_0]z^{-1} + r^2 z^{-2}}$	$ z > r$
$[r^n \sin \omega_0 n]u[n]$	$\frac{[r \sin \omega_0]z^{-1}}{1 - [2r \cos \omega_0]z^{-1} + r^2 z^{-2}}$	$ z > r$

Properties of the z -Transform:

$$X(z) = \sum_{n=-\infty}^{\infty} x[n]z^{-n}$$

$$x[n] = \frac{1}{2\pi j} \oint_C X(z)z^{n-1} dz$$

Property	Signal	z -Transform	ROC
	$x[n]$ $x_1[n]$ $x_2[n]$	$X(z)$ $X_1(z)$ $X_2(z)$	R R_1 R_2
Linearity	$ax_1[n] + bx_2[n]$	$aX_1(z) + bX_2(z)$	At least $R_1 \cap R_2$
Time Shifting	$x[n - n_0]$	$z^{-n_0}X(z)$	R , except possibly $z = 0$
z -Domain Scaling	$e^{j\omega_0 n}x[n]$	$X(e^{-j\omega_0}z)$	R
	$z_0^n x[n]$	$X\left(\frac{z}{z_0}\right)$	$z_0 R$
Time Reversal	$a^n x[n]$ $x[-n]$	$X\left(\frac{z}{a}\right)$ $X(z^{-1})$	$ a R$ R^{-1}
Time Expansion	$x_{(k)}[n] = \begin{cases} x[r], & n = rk \\ 0, & n \neq rk \end{cases} \quad r \in \mathbb{Z}$	$X(z^k)$	$R^{\frac{1}{k}}$
Conjugation	$x^*[n]$	$X^*(z^*)$	R
Convolution	$x_1[n] * x_2[n]$	$X_1(z)X_2(z)$	At least $R_1 \cap R_2$
First Difference	$x[n] - x[n - 1]$	$(1 - z^{-1})X(z)$	At least $R \cap \{ z > 0\}$
Accumulation	$\sum_{k=-\infty}^n x[k]$	$\frac{1}{1 - z^{-1}}X(z)$	At least $R \cap \{ z > 1\}$
z -Domain Differentiation	$nx[n]$	$-z \frac{d}{dz}X(z)$	R