

DIGITAL SIGNAL PROCESSING: A COMPUTER-BASED APPROACH

Fourth Edition

Errata List

Chapter 1

Page 2, Line 22 from top: Insert a period “.” After “*sampled-data signal*”.

Page 15, Line 3 from bottom: Insert “*Unvoiced sounds*” before “are”.

Page 16, Caption of Figure 1.14: Replace “CaliforniaEarthquake” with “California Earthquake”.

Chapter 2

Page 82, Problem 2.7, Part (d): Replace “ $\{x_4[n]\} = \{1, 1, 0, 0, 0, 1, 1\}$ ” with “ $\{x_4[n]\} = \{1, 0, 1, 0, 1, 0, 1\}$ ”.

Page 82, Problem 2.8, Part (b): Replace “ $0 \leq n \leq 5$ ” with “ $0 \leq n \leq 4$ ”.

Page 83, Problem 2.13: Replace “ $\{-3, 5, -6, 4\}$ ” with “ $\{-3, 5, -6, 4\}$ ”.

Page 83, Problem 2.14: Replace “ $\{n\}$ ” with “ $\{1\}$ ”.

Page 85, Problem 2.40, Part (e): Replace “ 0.75π ” with “ 0.7π ”.

Page 86, Problem 2.48, Part (iii): Replace “ $g[n] = \mu[n - N] - \mu[n - N]$ ” with “ $g[n] = \mu[n - M] - \mu[n - N]$ ”.

Page 87, Problem 2.48, Part (d): Replace “ $g[n] \otimes g[n]$ ” with “ $w[n] \otimes w[n]$ ”.

Page 87, Exercise M.1: Replace “Example 2.11” with “Example 2.8”.

Chapter 3

Page 123, Caption of Figure 3.17: Replace “ $\cos(6\pi t)$ ” with “ $\cos(6\pi t/\text{sec})$ ”, “ $\cos(14\pi t)$ ” with “ $\cos(14\pi t/\text{sec})$ ”, “ $\cos(26\pi t)$ ” with “ $\cos(26\pi t/\text{sec})$ ”.

Page 127, Line 2 below Eq. (3.84): Replace “ $\cos(6\pi t)$ ” with “ $\cos(6\pi t/\text{sec})$ ”.

Page 132, last line: Delete “and systems”.

Page 135, Problem 3.18, Part (e): Replace “ $y_f[n]$ ” with “ $y_5[n]$ ”.

Page 136, Problem 3.30: Replace “Figure P3.2” with “Figure P3.1”.

Page 137, Line above Problem 3.31: Replace “Figure P3.2” with “Figure P3.1”.

Page 137, Problem 3.33: Replace “Figure P3.1” with “Figure P3.2”.

Page 137, Line above Problem 3.34: Replace “Figure P3.1” with “Figure P3.2”.

Page 139, Problem 3.45: Insert “with itself” after “sequences”.

Page 139, Problem 3.46, part (b): Replace “ $G(e^{j(\omega+0.5\pi)})$ ” with “ $G(e^{j(\omega+0.5\pi)})$ ”.

Chapter 4

Page 144, Eq. (4.1): Replace “ $\frac{1}{M} \sum_{\ell=0}^{M-1} x[n-\ell]$ ” with “ $\sum_{\ell=-\infty}^n x[\ell]$ ”.

Page 152, Line 2 of Example 4.5: Replace “The demonstrate” with “To demonstrate”.

Page 167, Line 6 from bottom: Replace “(4.29)” with “(4.32)”.

Page 170, Line 7 above Example 4.28: Replace “(p, d, x, si]” with “(p, d, x, si)”.

Page 191, Line 2 below Eq. (4.109): Replace “when” with “where”.

Page 197, Problem 4.79, Part (d): Replace “ $H_e(e^{j\omega})$ ” with “ $H_d(e^{j\omega})$ ”.

Page 197, Problem 4.79, Part (e): Replace “ $H_d(e^{j\omega})$ ” with “ $H_e(e^{j\omega})$ ”.

Page 198, Section 4.12: Delete MATLAB Exercises M4.7, M4.8, and M4.9.

Chapter 5

Page 207, Eq. (5.35): Replace “ $\sum_{n=0}^{N-1} x[n]e^{-j2\pi k / N}$ ” with “ $\sum_{n=0}^{N-1} x[n]e^{-j2\pi kn / N}$ ”.

Page 208, Figure 5.3: Replace “ 0.2π ” with “ 0.4π ,” “ 0.4π ” with “ 0.8π ,” “ 0.6π ” with “ 1.2π ,” “ 0.8π ” with “ 1.6π ,” “ π ” with “ 2π ,” and “ ω/π ” with “ ω .”

Page 262, Problem 5.2, Last line: Replace “5” with “6”.

Page 265, Problem 5.21: Replace it with the following:

“Show that the N -point DFT $X[k]$ of a length- N sequence $x[n]$ can be computed as follows

[Gol69b]: (1) Generate a length- N sequence $g[n]$ by multiplying $x[n]$ with the sequence $W_N^{-n^2/2}$,

(2) Compute $r_{yg}[k]$, the correlation for lag k of the sequences $y[n] = W_N^{n^2/2}$ and $g[n]$, and (3)

Multiply $r_{yg}[k]$ by the sequence $W_N^{-k^2/2}$ to yield $X[k]$.

Page 265, Problem 5.22, Line 4: Replace “ $Y[k], 0 \leq k \leq N - 1$ ” with “ $Y[k], 0 \leq k \leq 3N - 1$ ”.

Replace “ $W[k]$ ” with “ $W[\ell]$ ”.

Page 266, Problem 5.29: Replace “8-point” with “6-point”, and “length-8” with “length-6”.

Page 268, Problem 5.45: Replace “12-point” with “10-point”.

Page 268, Problem 5.46: Replace “12-point” with “10-point”, and “five” with “four”.

Page 269, Problem 5.49: Replace “ $\{b_1[n]\} = \{-5, 2, 6, 4\}$ ” with

“ $\{b_1[n]\} = \{-5, 6, 2, 4\}$ ”, and “ $\{y_d[n]\} = \{-52, 42, 50, 19\}$ ” with

“ $\{y_d[n]\} = \{-32, 54, 10, -11\}$ ”.

Page 270, Problem 5.60: Replace

“ $\{6.29, 8.11, -7.46, 8.26, 2.64, -8.04, -4.43, 0.93, -9.15, 9.29\}$ ” with

“ $\{6.29, 8.11, -7.46, 8.26, 2.64, -8.04, -4.43, 0.93, -9.15, 9.29\}$ ”.

Page 271, Problem 5.62: Replace “ $X[k_1] = 6.1 - j4.2$ ” with “ $X[k_1] = 6.1 + j2.8$ ”,

“ $X[k_2] = 9.1 - j3.8$ ” with “ $X[k_2] = -7.3 - j9.5$ ”, “ $X[k_3] = -3.3 + j2.5$ ” with

“ $X[k_3] = 4.13 + j8.27$ ”, and “ $X[k_4] = 4.3 + j9.5$ ” with “ $X[k_4] = -3.15 + j2.04$ ”.

Page 271, Problem 5.63: Replace “ $X[k_1] = 8.12 - j7.56$ ” with “ $X[k_1] = -3.6 + j5.46$ ”,

“ $X[k_2] = -3.6 - j2.23$ ” with “ $X[k_2] = j3.78$ ”, “ $X[k_3] = \gamma + j3.78$ ” with

“ $X[k_3] = \gamma - j7.91$ ”, and “ $X[k_4] = 4.52 - j2.2$ ” with “ $X[k_4] = -3.7 - j7.56$ ”.

Page 271, Problem 5.65: Replace “ $1.0 + 24.25$ ” with “ $1.0 + j24.25$ ”.

Page 272, Problem 5.74, 3rd line: Replace “ $x[n]$ ” with “ $x[n]$ ”.

Page 272, Problem 5.72: Replace “[?]” with “[Gun2002]”.

Page 275, Line above Eq. (5.212): Replace “ $\alpha_2^2 = \alpha_2^2$ ” with “ $\alpha_1^2 = \alpha_2^2$ ”.

Chapter 6

Page 289, Line below Eq. (6.29): Replace “ $g[n]:$ ” with “ $g[n]$ ”.

Page 305, Line above Eq. (6.71): Replace “ X ” with “ $X(z)$ ”.

Page 306, Line 2 above Section 6.6.2: Replace “ $\{y[n]\}$ ” with “ $y[n]$ ”.

Page 307, First line: Replace “ $2N - 1$ ” with “ $2N - 2$ ”.

Page 307, Eq. (6.73): Replace “ $y_L[2N - 1]z^{-(2N-1)}$ ” with “ $y_L[2N - 2]z^{-(2N-2)}$ ”.

Page 320, Problem 6.3: Replace “ $x[n] = \frac{1}{z!} \mu(z)$ ” with “ $x[n] = \frac{1}{n!} \mu[n]$ ”.

Page 320, Problem 6.4: Replace “ $H(z)$ ” with “ $X(z)$ ”.

Page 322, Problem 6.13(c): Replace “ $(1 - 0.4z^{-2})^2$ ” with “ $(1 - 0.4z^{-1})^2$ ” in the denominator of “ $X_c(z)$ ”.

Page 322, Problem 6.20: Replace “ $X(z)|_{z=e^{j(2\pi k/9)}}$ ” with “ $X(z)|_{z=e^{j(2\pi k/8)}}$ ”, and replace “ $0 \leq k \leq 8$ ” with “ $0 \leq k \leq 7$ ”.

Page 323, Problem 6.25: Replace “four” with “three”.

Page 324, Problem 6.32, Part (d): Replace “ $-1 < |z| < 1$ ” with “ $|z| > 1$ ”.

Page 324, Problem 6.33: Insert “ $\frac{1}{2\pi j}$ ” in front of each integral as shown below

$$\frac{1}{2\pi j} \oint_C X(z)U(z)V(z)z^{-1} dz = \left[\frac{1}{2\pi j} \oint_C X(z)z^{-1} dz \right] \left[\frac{1}{2\pi j} \oint_C U(z)z^{-1} dz \right] \left[\frac{1}{2\pi j} \oint_C V(z)z^{-1} dz \right].$$

Page 328, Problem 6.57: Replace “ $H(e^{j3\pi/4})$ ” with “ $H(e^{j3\pi/2})$ ”.

Page 328, Problem 6.58: Replace “ $H(e^{j\pi}) = 20$ ” with “ $H(e^{j\pi}) = 2$ ”, and “ $H(e^{j3\pi/4})$ ” with “ $H(e^{j3\pi/2})$ ”.

Page 329, Eq. (6.120): Replace “ $D(z^1)$ ” with “ $D(z^{-1})$ ”.

Page 332, Problem 6.85: Insert a period “.” after “ -3.0 ”.

Chapter 7

Page 337: Line 4 from top: Delete “ \ddot{A} ”.

Page 348, Line above Eq. (7.37): Replace “ $|H(e^{j\omega})| = |H_m(e^{j\omega})|$ ” with “ $|H(e^{j\omega})| = |H_m(e^{j\omega})|$ ”.

Page 355, last line: Replace “ $-6\sin(\omega) + 4\sin(2\omega) + 2\sin(3\omega)$ ” with “ $6\sin(\omega) - 4\sin(2\omega) + 2\sin(3\omega)$ ”.

Page 366, Line 4 above Eq. (7.80): Replace “ $\sqrt{\alpha}$ ” with “ $\sqrt{\alpha}$ ”.

Page 374, Line 2 of Section 7.4.5: Replace “ $(\omega = 0$ ” with “ $(\omega = 0)$ ”.

Page 375, Line 7 below Eq. (7.108): Replace “7.3” with “M7.3”.

Page 405, Problem 7.30(c): Replace “ $H_3(z)$ ” with “ $H_4(z)$ ”.

Page 410, Problem 7.75: Replace “ H_{AI} ” with “ $H_{AI}(z)$ ”.

Page 411, Problem 7.86: Replace “[?]” with “[Reg87b]”.

Page 411, Problem 7.87(a): Replace “ $3.9 + 3.9z^{-1}$ ” with “ $2.2 + 2.2z^{-1}$ ”.

Page 412, Problem 7.89(a): Delete “)” in the numerator of $H_a(z)$.

Page 412, Problem 7.91: Replace “ $0 \leq n \leq 2}$ ” with “ $0 \leq n \leq 2,$ ”.

Page 415, MATLAB Exercise M7.12: Replace “ 0.5π ” with “ 0.4π ”.

Chapter 8

Page 421, Figure 8.4: Replace the structure of Fig. 8.4(c) with the structure shown below:

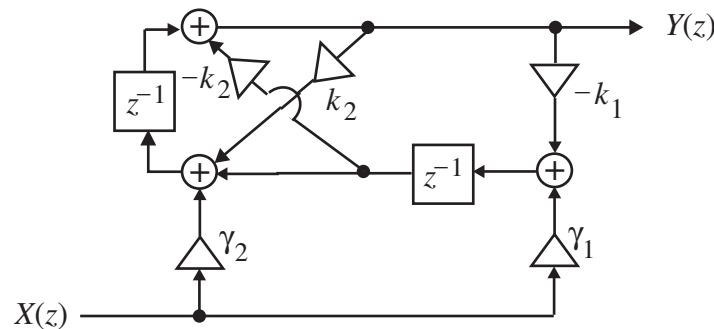

Page 453, Line above Eq. (8.85a): Replace “ $\{H_i(z), G_i(z)\}$ ” with “ $\{H_i(z), G_i(z)\},$ ”.

Page 456, Line 2 from top: Replace “ $z^{-N} H_n(z^{-1})$ ” with “ $z^{-N} H_N(z^{-1})$ ”.

Page 456, Line below Eq. (8.94): Replace “ a_i^i / a_0^i ” with “ $a_i^{(i)} / a_0^{(i)}$ ”.

Page 457, Line 9 below Eq. (8.98b): Replace “ $H(z)$ ” with “ $H_4(z)$ ”, and “ $G(z)$ ” with “ $G_4(z)$ ”.

Page 482, Problem 8.47: Replace “six” with “seven”.

Page 483, Problem 8.54: Replace “ $G_3(z) = 1 + 2z^{-1} + 3z^{-3}$ ” with “ $G_3(z) = 1 + 2z^{-1} + 3z^{-2}$ ”.

Page 484, Problem 8.60, Part (c): Replace “ -0.875 ” with “ 0.875 ” in the numerator of $H_3(z)$.

Page 484, Problem 8.60, Part (d): Replace “ $1 - 2.8z^{-1} + z^{-2}$ ” with “ $1 + 2.8z^{-1} + z^{-2}$ ” in the numerator of $H_4(z)$.

Page 488, Exercise M8.8: Replace “lowpass” in the first line with “highpass”.

Page 488, Exercise M8.9: Replace “lowpass” in the first line with “bandpass”.

Chapter 9

Page 516, Line 2 below Eq. (9.55): Replace “ $p_{i\ell}$ ” with “ p_i ”, and “ $d_{i\ell}$ ” with “ d_i ”.

Page 517, Eq. (9.60): Replace “ $p_{i\ell}$ ” with “ $p_{i,\ell}$ ”, and “ $d_{i\ell}$ ” with “ $d_{i,\ell}$ ”.

Page 517, Eq. (9.61): Replace “ $p_{i\ell}$ ” with “ $p_{i,\ell}$ ”, and “ $d_{i\ell}$ ” with “ $d_{i,\ell}$ ”.

Page 517, Eq. (9.63): Replace “ $a_{i\ell}$ ” with “ $a_{i,\ell}$ ”.

Page 517, Line 2 from bottom: Replace “ $a_{1\ell}$ ” with “ $a_{1,\ell}$ ”, and “ $a_{2\ell}$ ” with “ $a_{2,\ell}$ ”.

Page 522, Problem 9.19: Replace “ $H_{LP}(z)$ ” with “ $H_{LP}(s)$ ”.

Page 522, Problem 9.20: Replace “ $H_{LP}(z)$ ” with “ $H_{HP}(s)$ ”.

Chapter 10

Page 542, Line 7 from top: Replace “ 55.6π ” with “ 5.56π ”.

Page 548, Eq. (10.60): Replace the equation with

$$c[1] = \tilde{c}[0] - \frac{1}{2}\tilde{c}[2],$$

$$c[k] = \frac{1}{2}(\tilde{c}[k-1] - \tilde{c}[k+1]), \quad 2 \leq k \leq \frac{N}{2} - 1,$$

$$c\left[\frac{N}{2} - 1\right] = \frac{1}{2}\tilde{c}\left[\frac{N}{2} - 2\right], \quad c\left[\frac{N}{2}\right] = \frac{1}{2}\tilde{c}\left[\frac{N}{2} - 1\right].$$

Page 549, Eq. (10.69): Replace “ $\frac{N}{2} - 1$ ” with “ $\frac{N}{2}$ ” in the third line.

Page 553, Line 6 below Eq. (10.76): Replace “frequencies” with “extremal points on x ”.

Page 581, Line above Section 10.6.3: Replace “25” with “47”.

Page 585, Line 4 from bottom: Replace “ $N_{I_1} = 136$ ” with “ $N_{I_2} = 136$ ”.

Page 594, Problem 10.49: Replace “ $q_{r,s} = q_{r-1,s} + \alpha q_{r,s-1} - \alpha q_{r-1,s}$ ” with “ $q_{r,s} = q_{r-1,s} - \alpha q_{r,s-1} + \alpha q_{r-1,s}$ ”.

Page 594, Problem 10.49: Replace “ $\omega_p = 0.09\pi, \omega_s = 0.02\pi$ ” with “ $\omega_p = 0.02\pi, \omega_s = 0.09\pi$ ”.

Page 596, Exercise M10.21: Replace “30” in the first line with “32”.

Chapter 11

Page 616, Line 3 from bottom: Insert a period “.” after “11.1.4”.

Page 619, Line 2 above Eq. (11.32): Replace “11.31” with “(11.31)”.

Page 639, Eq. (11.80a): Replace “ $\langle 5n_1 + 3n_2 \rangle_5$ ” with “ $\langle 5n_1 + 3n_2 \rangle_{15}$ ”.

Page 639, Eq. (11.80b): Replace “ $\langle 10k_1 + 6k_2 \rangle_5$ ” with “ $\langle 10k_1 + 6k_2 \rangle_{15}$ ”.

Page 639, Eq. (11.81): Replace “ $X[\langle 10k_1 + 6k_2 \rangle_5]$ ” with “ $X[\langle 10k_1 + 6k_2 \rangle_{15}]$ ”.

Chapter 12

Page 685, Line below Eq. (12.74): Replace “(12.77)” with “12.74”.

Chapter 13

Page 764, Example 13.12: Line 6: Replace “ z^2 ” with “ z^{-2} ” in the expression for $H(z)$.

Page 768, Line 6 below Eq. (13.51): Replace “The structure for the case $L < M$ ” with “The structure for the case $L > M$ ”.

Page 795, Line 2 above Eq. (13.126): Replace “ K ” with “ M ”.

Page 795, Eq. (13.127): Replace “ $z^{-1}(1 + 5z^{-2} + 10z^{-4})$ ” with “ $z^{-1}(5 + 10z^{-2} + z^{-4})$ ” and “ $E_1(z^2)$ ” with “ $z^{-1}E_1(z^2)$ ”.

Page 795, Eq. (13.128): Replace “ $E_1(z) = 1 + 5z^{-1} + 10z^{-2}$ ” with “ $E_1(z) = 5 + 10z^{-1} + z^{-2}$ ”.

Page 803, Problem 13.6(b): Replace “ $G(z^{1/L}W_L^k)$ ” with “ $G(z^{1/L}W_L^{-k})$ ”.

Page 803, Problem 13.47: Line 3 below Eq. (13/.135): Replace “ $H_L(z)Q(z)H_M(z)$ ” with “ $H_L(z^L)Q(z)H_M(z^M)$ ”.

Page 803, Problem 13.47: Lines 4 and 5 below Eq. (13/.135): Replace “ $z^{-\ell}$ ” with “ z^{-1} ”.

Chapter 14

Page 812, Line below Eq. (14.13): Replace “14.13” with “(14.13)”.

Page 817, Line above Eq. (14.30): Replace “[?]” with “[Str96]”.

Page 817, Line 5 above Eq. (14.33a): Replace “ $2z^{-1}$ ” with “ z^{-1} ”.

Page 818, Line below Eq. (14.38): Replace “[?]” with “[Str96]”.

Page 853, Problem 14.2: Replace “ $z^{-5}H_0(z^{-1})$ ” with “ $z^{-3}H_0(z^{-1})$ ”.

Page 857, Problem 14.28, part (a): Replace “0.562” with “0.56”.

Page 859, Problem 14.43, part (a): Replace the expression for $H_0(z)$ with the following: “ $H_0(z) = 1 - 0.5z^{-1} + 0.78z^{-2} + 0.36z^{-3} - 0.4z^{-4} - 0.8z^{-5}$ ”.

Page 859, Problem 14.43, part (b): Replace the expression for $H_0(z)$ with the following: “ $H_0(z) = 1 + 3z^{-1} - 5z^{-2} - 65z^{-3} + 12z^{-4} - 4z^{-5}$ ”.

July 30, 2011